



# ESP-C3-M1 Specification

Version V1.1.1

Copyright©2021



## Content

1. Product Overview.....	4
1.1. Features.....	5
2. Main parameters.....	6
2.1. Static electricity requirements.....	7
2.2. Electrical characteristics.....	7
2.3. WIFI RF performance.....	7
2.4. BLE RF performance.....	8
2.5. Power consumption.....	8
3. Appearance dimensions.....	10
4. Pin definition.....	11
5. Schematic diagrams.....	14
6. Antenna parameters.....	15
6.1. Test conditions of antenna.....	15
6.2. Antenna S parameters.....	16
6.3. Antenna gain and efficiency.....	16
6.4. Antenna pattern.....	17
7. Design guidance.....	18
7.1. Module application guidance circuit.....	18
7.2. Antenna layout requirements.....	18
7.3. Power supply.....	19
7.4. The use of GPIO interface.....	20
8. Reflow soldering curve diagram.....	21
9. Product related models.....	22
10. Packaging information.....	23
11. Contact us.....	<b>错误! 未定义书签。</b>
Disclaimer and copyright notice.....	24
Notice.....	24

## 1. Product Overview

ESP-C3-M1 is a WiFi module developed by Shenzhen Ai-Thinker Technology Co., Ltd. The module's core processor chip ESP32-C3 is a highly integrated low-power WiFi and Bluetooth system-on-chip (SoC), designed for the Internet of Things (IoT), mobile devices, wearable electronic devices, smart homes application, etc.

The ESP32-C3 chip has industry-leading low power consumption performance and radio frequency performance, and supports WiFi IEEE802.11b/g/n protocol and BLE 5.0. The chip is equipped with a RISC-V 32-bit single-core processor with a working frequency of up to 160 MHz. Support secondary development without using other microcontrollers or processors. The chip has built-in 400 KB SRAM, 384 KB ROM, 8KB RTC SRAM, and built-in 4MB Flash. The chip supports a variety of low power consumption working states, which can meet the power consumption requirements of various application scenarios. The chip's unique features such as fine clock gating function, dynamic voltage clock frequency adjustment function, and RF output power adjustable function can achieve the best balance between communication distance, communication rate and power consumption.

The ESP-C3-M1 module provides a wealth of peripheral interfaces, including UART, PWM, SPI, I2S, I2C, ADC, temperature sensor and up to 15 IO interfaces.

The ESP-C3-M1 module has a variety of unique hardware security mechanisms. The hardware encryption accelerator supports AES, SHA and RSA algorithms. Among them, RNG, HMAC and digital signature (Digital Signature) modules provide more security features. Other security features include Flash encryption and secure boot (secure boot) signature verification. The perfect security mechanism enables the chip to be perfectly applied to various encryption products.

The ESP-C3-M1 module supports low-power Bluetooth: Bluetooth5, Bluetooth mesh. Bluetooth rate support: 125Kbps, 500Kbps, 1Mbps, 2Mbps. Support broadcast extension, multi-broadcasting, channel selection.

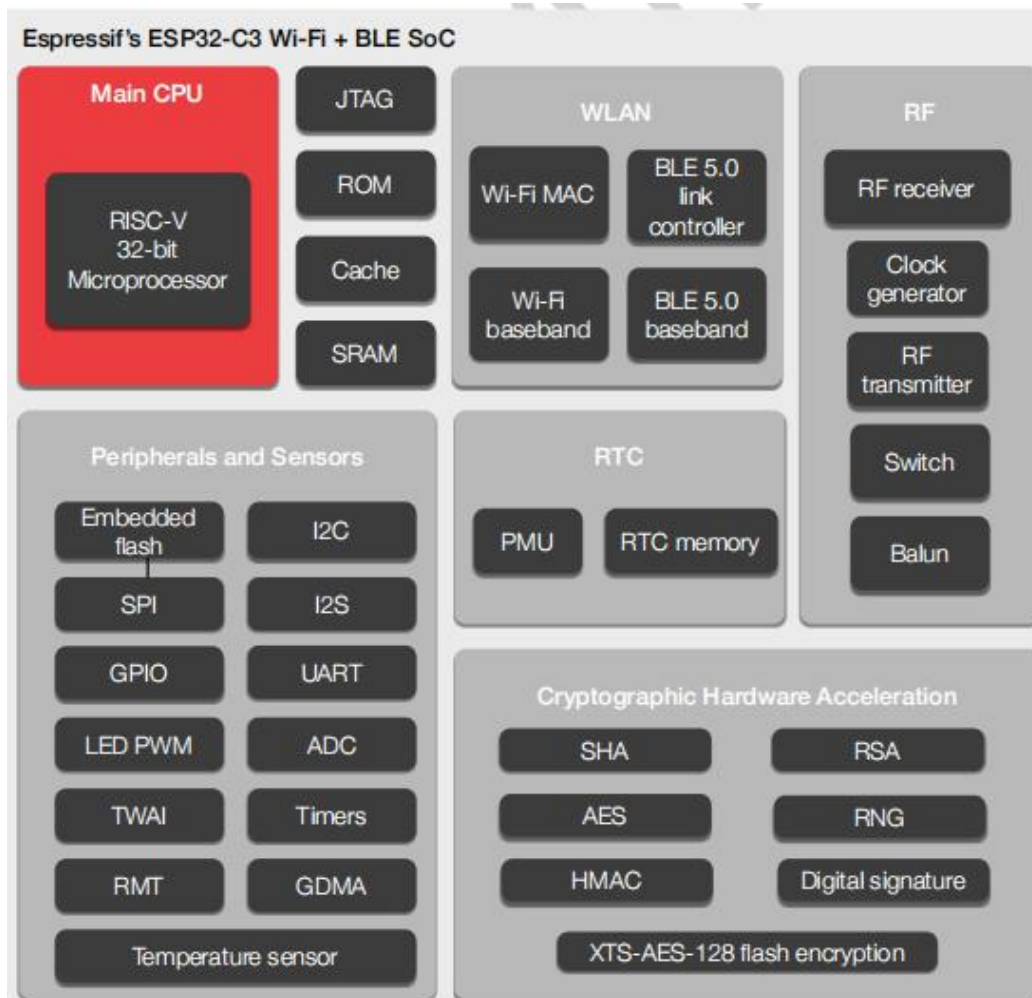

**Figure 1 The main chip architecture diagram**

## 1.1. Features

- Support WiFi 802.11b/g/n, 1T1R mode data rate up to 150Mbps
- Support BLE5.0, rate support: 125Kbps, 500Kbps, 1Mbps, 2Mbps
- RISC-V 32-bit single-core processor, supports a clock frequency of up to 160 MHz, has 400 KB SRAM, 384 KB ROM, 8KB RTC SRAM
- Support UART/GPIO/ADC/PWM/I2C/I2S/SPI interface, temperature sensor, pulse counter
- SMD-61 Package
- Integrated WiFi MAC/BB/RF/PA/LNA/Bluetooth
- Support multiple sleep modes, deep sleep current is less than 5uA

- Serial port rate up to 5Mbps
- Support STA/AP/STA+AP mode and promiscuous mode
- Support Smart Config (APP)/AirKiss (WeChat) for Android and IOS one-click network configuration
- Support serial port local upgrade and remote firmware upgrade (FOTA)
- General AT commands can be used quickly
- Support secondary development, integrated Windows and Linux development environment
- About Flash: ESP-C3-M1 chip has built-in 4MByte Flash by default

## 2. Main parameters

**Table 1 Main parameters**

<b>Module name</b>	ESP-C3-M1
<b>Package</b>	SMD-61
<b>Size</b>	16.6*13.2*2.4(±0.2)mm
<b>Antenna</b>	On-board PCB antenna
<b>Frequency Range</b>	2400 ~ 2483.5MHz
<b>Working Temperature</b>	-40 °C ~ 85 °C (C3FN4 Normal temperature version)
	-40 °C ~ 105 °C(C3FH4 High temperature version)
<b>Store Temperature</b>	-40 °C ~ 125 °C , < 90%RH
<b>Power supply range</b>	Voltage: 3.0V ~ 3.6V, Electrical current >500mA
<b>Support Interface</b>	UART/GPIO/ADC/PWM/I2C/I2S/SPI
<b>IO</b>	IO0,IO1,IO2,IO3,IO4,IO5,IO6,IO7,IO8,IO9,IO10,IO18,IO19,IO20,IO21
<b>UART Rate</b>	Support 110 ~ 4608000 bps , default 115200 bps
<b>Bluetooth</b>	BLE 5.0,Does not support traditional Bluetooth
<b>Security</b>	WEP/WPA-PSK/WPA2-PSK
<b>SPI Flash</b>	4MByte

## 2.1. Static electricity requirements

The ESP-C3-M1 module is an electrostatic sensitive device, and special precautions must be taken when handling it.



Figure 2 ESD anti-static diagram

## 2.2. Electrical characteristics

Table 2 Electrical characteristics table

Parameters	Conditions	Min	Typical Values	Max	Unit	
Supply voltage	VDD	3.0	3.3	3.6	V	
I/O	V <sub>IL</sub> /V <sub>IH</sub>	-	-0.3/0.75VDD	-	0.25VDD/VDD+0.	V
	V <sub>OL</sub> /V <sub>OH</sub>	-	N/0.8VIO	-	0.1VIO/N	V
	I <sub>MAX</sub>	-	-	-	12	mA

## 2.3. WIFI RF performance

Table 3 WiFi RF performance table

Description	Typical values			Unit
Working frequency	2400 - 2483.5			MHz
<b>Output power</b>				
Mode	Min	Typical values	Max	Unit
11n mode HT40, MCS7	13	15	17	dBm
11n mode HT20, MCS7	13	15	17	dBm
11g mode, 54Mbps	14	16	18	dBm
11b mode, 11Mbps	16	18	20	dBm
<b>Receiving sensitivity</b>				
Mode	Min	Typical values	Max	Unit
11b, 1 Mbps	-	-96	-	dBm
11b, 11 Mbps	-	-88	-	dBm

11g, 6 Mbps	-	-91	-	dBm
11g, 54 Mbps	-	-75	-	dBm
11n,HT20 (MCS7)	-	-73	-	dBm
11n,HT40 (MCS7)	-	-70	-	dBm

## 2.4. BLE RF performance

**Table 4 BLE RF performance table**

Description	Typical Values			Unit
<b>Output power</b>				
Mode	Min	Typical Values	Max	Unit
Transmit power	-	9	-	dBm
<b>Receiving sensitivity Low Energy consumption BLE: 1M</b>				
Mode	Min	Typical Values	Max	Unit
Sensitivity@30.8%PER	-	-94	-	dBm

## 2.5. Power consumption

The following power consumption data is based on 3.3V power supply, 25°C ambient temperature, and measured with an internal voltage regulator.

- All measurements are done at the antenna interface without the SAW filter.
- All emission data is based on 100% duty cycle, measured in continuous emission mode.

**Table 5 Power consumption table**

Mode	Min	Typical Values	Max	Unit
Tx 802.11b, DSSS 1Mbps, POUT=+20dBm	-	350	-	mA
Tx 802.11g, OFDM 54Mbps, POUT =+18dBm	-	290	-	mA
Tx 802.11n, MCS7, POUT =+17dBm	-	280	-	mA
Rx 802.11b, 1024bit	-	84	-	mA



Rx 802.11g, 1024bit	-	87	-	mA
Rx 802.11n, 1024bit	-	87	-	mA
Modem-Sleep	-	20	-	mA
Light-Sleep	-	130	-	μA
Deep-Sleep	-	5	-	μA
Power Off <sup>①</sup>	-	330 (Default module)	-	μA
	-	1 (Customized module)	-	μA

Remark:

①The power off state is to pull down the CHIP\_EN pin of the chip to make the chip in the off state.

Because the CHIP\_EN pin needs to be pulled up when the module is working normally, the CHIP\_EN pin inside the module reserves a 10K pull-up resistor.

The module is shipped by default, the pull-up resistor is attached, and the power off power consumption is 330uA at this time. If you have special requirements for Power off power consumption, you can customize the module. Remove the 10K pull-up resistor, and the power consumption of Power off can be as low as 1uA at this time.

### 3. Appearance dimensions

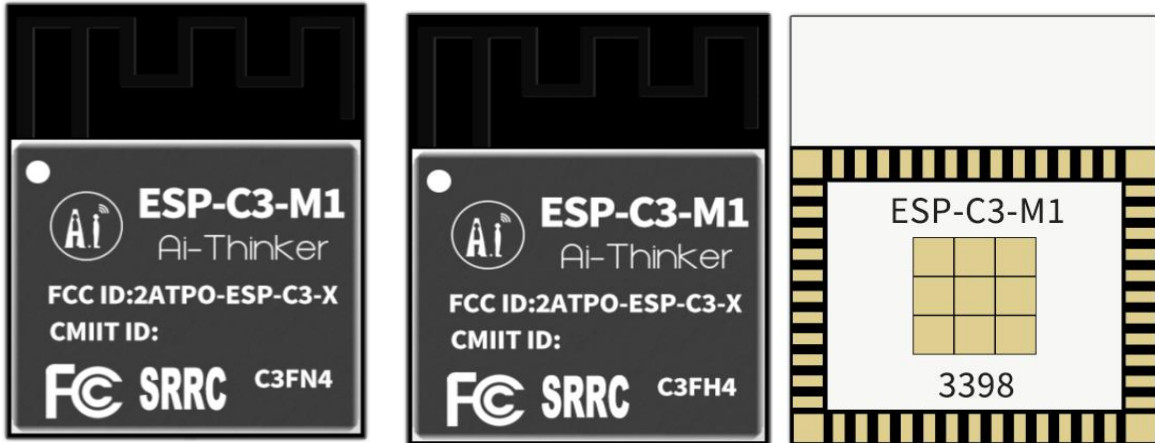

Figure 3 The appearance of the module (the rendering is for reference only, the actual product shall prevail)

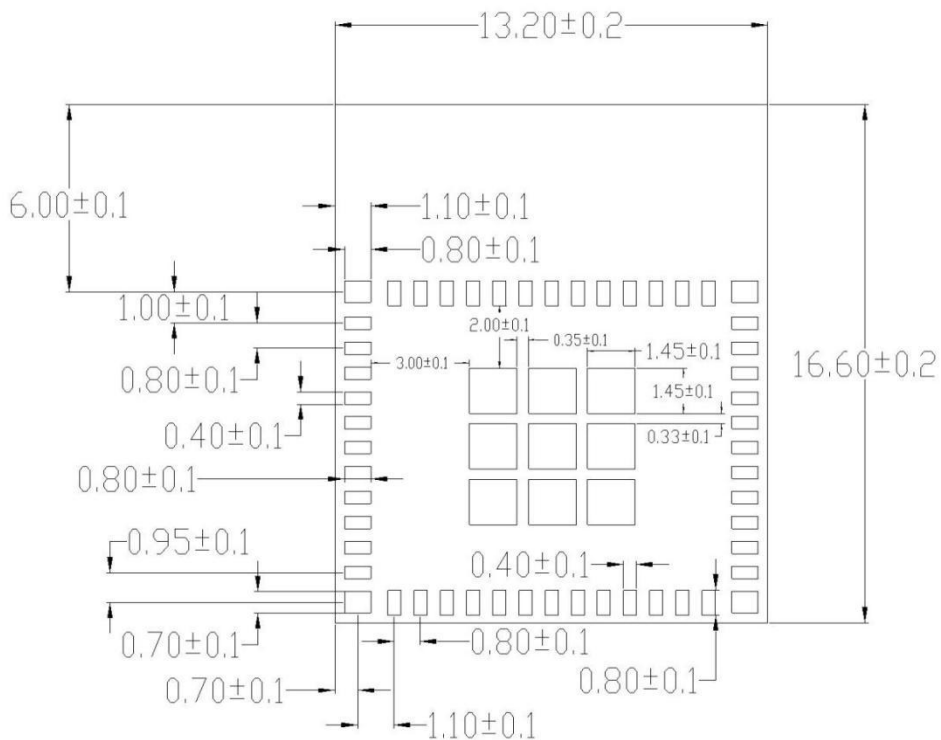
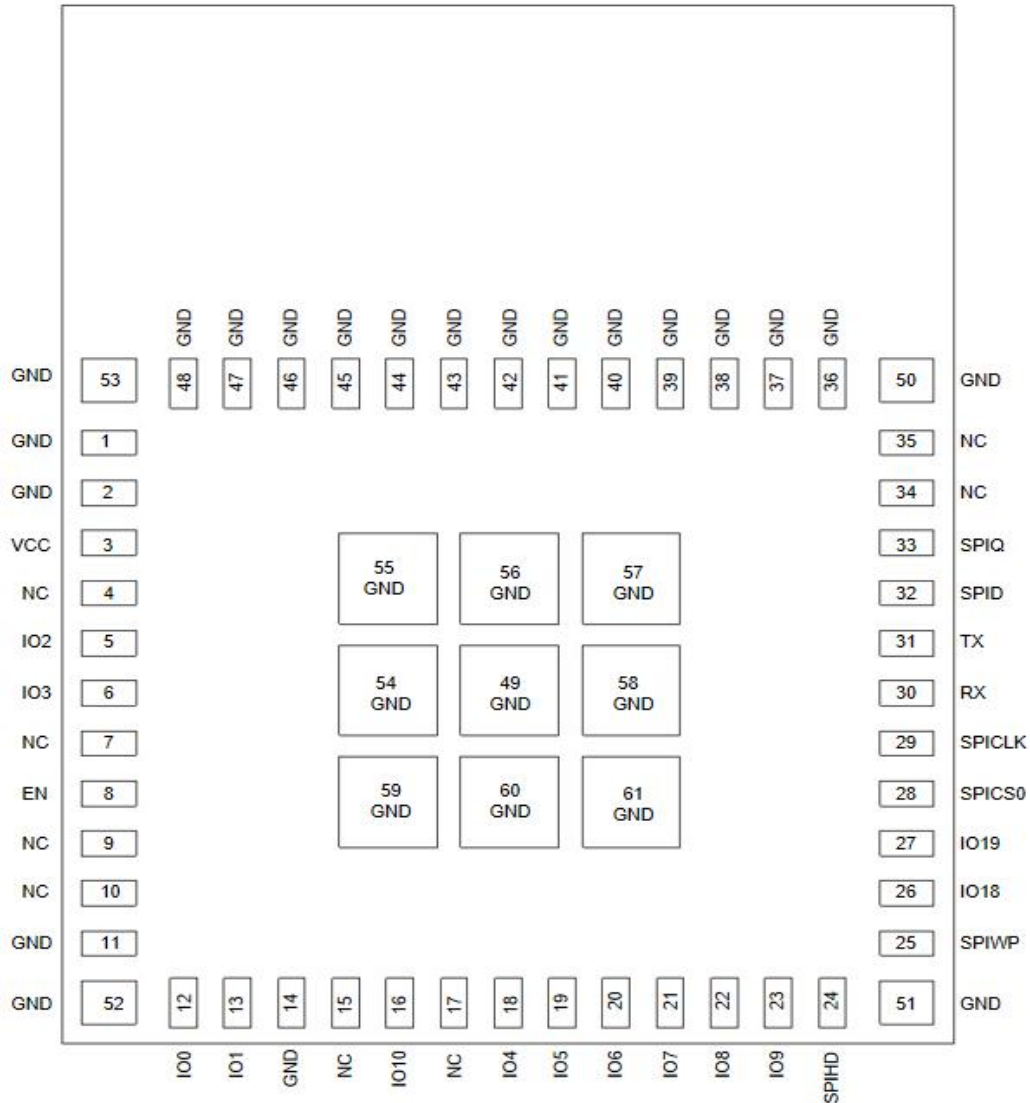

Figure 4 Module size diagram

## 4. Pin definition

The ESP-C3-M1 module has a total of 61 pins. As shown in the pin diagram, the pin function definition table is the interface definition.



**Figure 5 Schematic diagram of module pins (top view)**

**Table 6 Pin function definition table**

No.	Name	Function
1, 2, 11, 14, 36-61	GND	Grounded Power negative
3	VCC	Power Power positive
4, 7, 9, 10 15, 17, 34, 35	NC NC	Empty
5	IO2	GPIO2,ADC1_CH2,FSPIQ
6	IO3	GPIO3,ADC1_CH3
8	EN	High level: chip enabled; Low level: chip shutdown;
12	IO0	GPIO0,ADC1_CH0,XTAL_32K_P
13	IO1	GPIO1,ADC1_CH1,XTAL_32K_N
16	IO10	GPIO10,FSPICS0
18	IO4	GPIO4,ADC1_CH4,FSPIHD,MTMS
19	IO5	GPIO5,ADC2_CH4,FSPIWP,MTDI
20	IO6	GPIO6,FSPICLK,MTCK
21	IO7	GPIO7,FSPID,MTDO
22	IO8	GPIO8
23	IO9	GPIO9
24	SPIHD	NC,not recommended
25	SPIWP	NC,not recommended
26	IO18	GPIO18,USB_D-
27	IO19	GPIO19,USB_D+
28	SPICS0	NC,not recommended
29	SPICLK	NC,not recommended
30	RX	U0RXD,GPIO20
31	TX	U0TXD,GPIO21
32	SPID	NC, not recommended
33	SPIQ	NC, not recommended

**Table 7 Module startup mode description**

System start-up mode			
Pin	Default	SPI Start up mode	Download Start up Mode
IO8	Non	/	1
IO9	Pull up	1	0

Note: Some pins have been internally pulled up, please refer to the schematic diagram.

## 5. Schematic diagrams

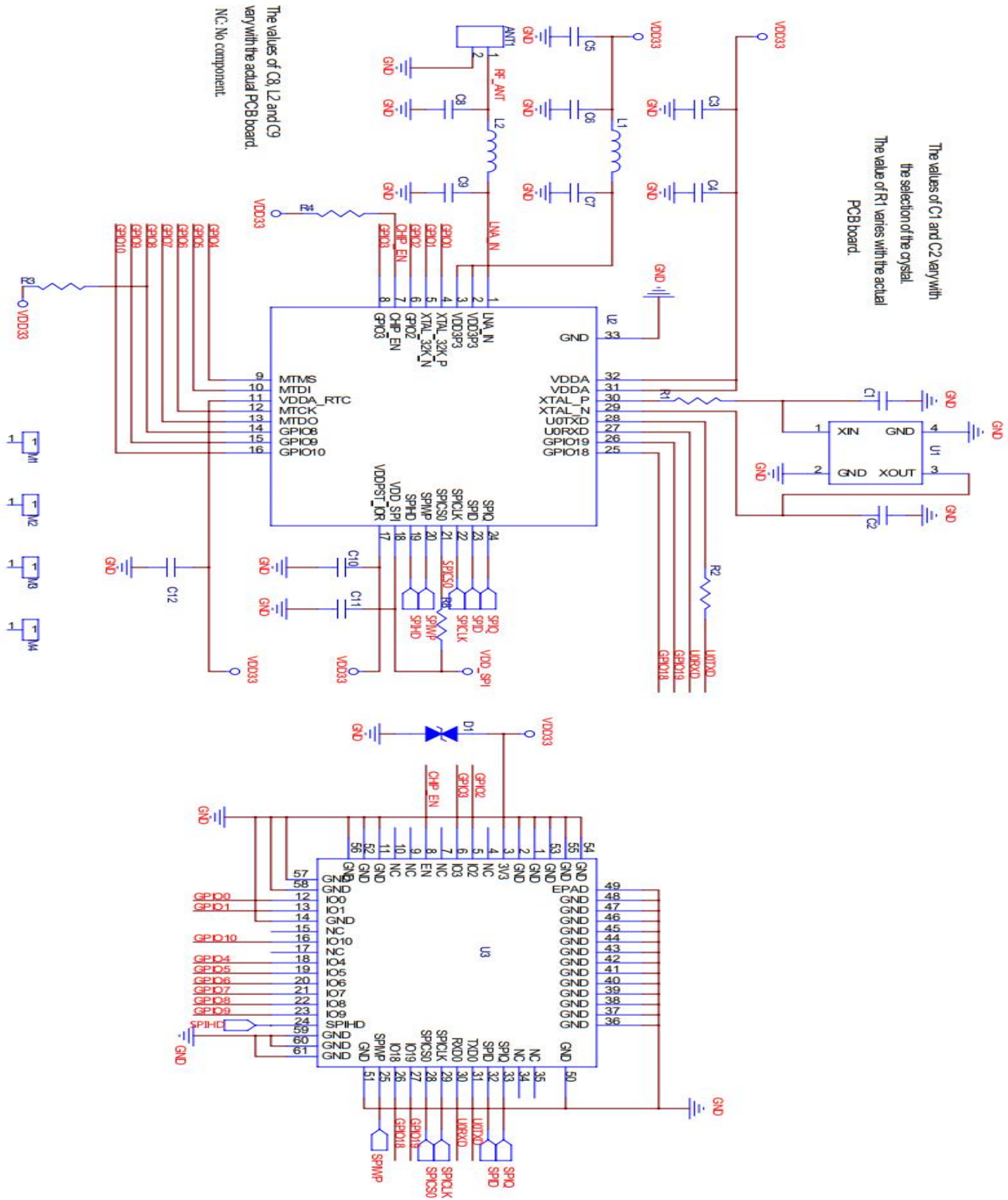

Figure 6 Module schematic diagram

## 6. Antenna parameters

### 6.1. Test conditions of antenna



**Figure 7 Antenna test conditions**

## 6.2. Antenna S parameters

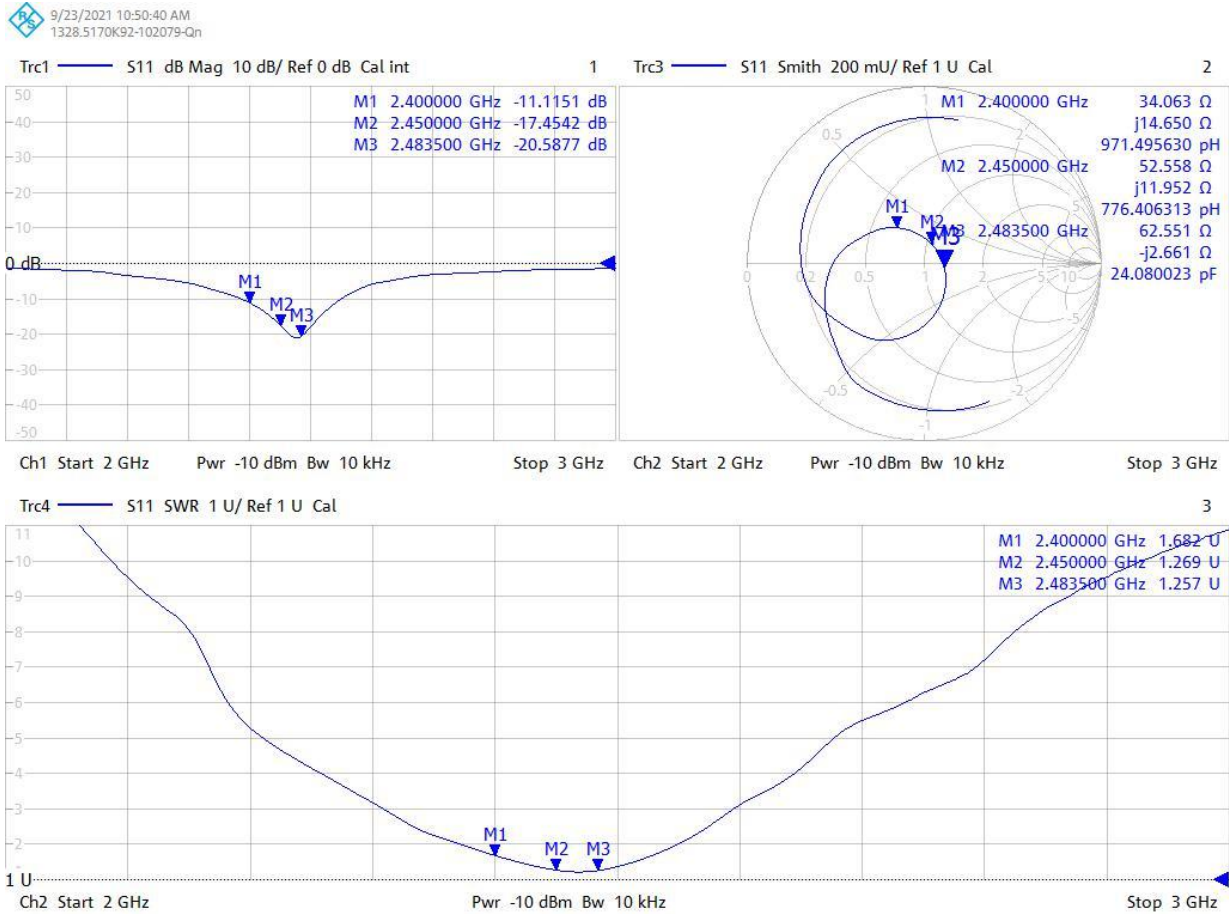

Figure 8 Antenna S parameters

## 6.3. Antenna gain and efficiency

Table 8 Antenna gain and efficiency

Frequency ID	1	2	3	4	5	6	7	8	9	10	11
Frequency (MHz)	2400.0	2410.0	2420.0	2430.0	2440.0	2450.0	2460.0	2470.0	2480.0	2490.0	2500.0
Gain (dBi)	2.22	2.33	2.17	2.36	2.39	2.66	2.76	2.73	2.60	2.68	2.46
Efficiency (%)	51.82	53.28	51.76	54.30	54.53	57.77	59.73	60.40	59.74	62.50	61.58



## 6.4. Antenna pattern

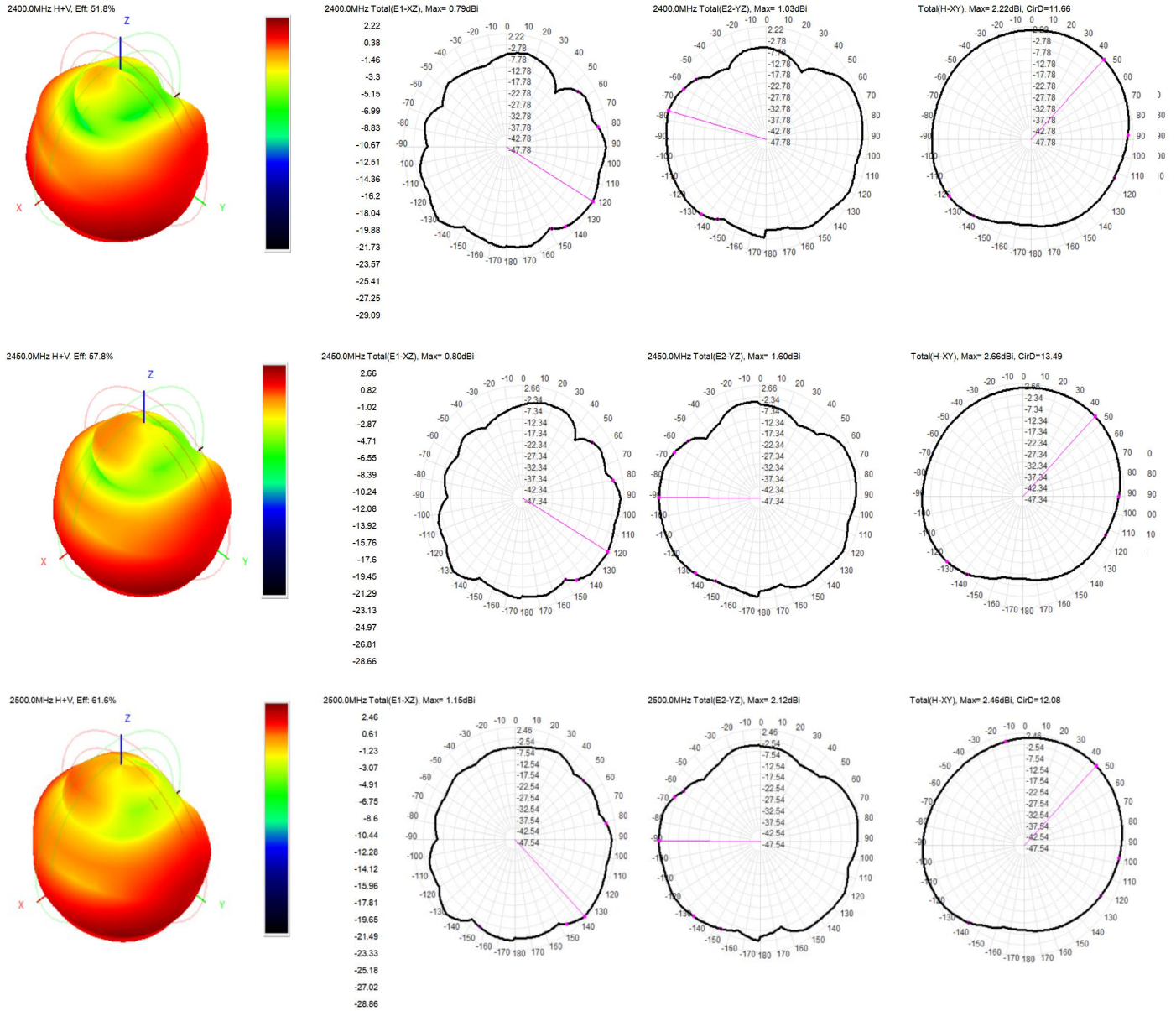
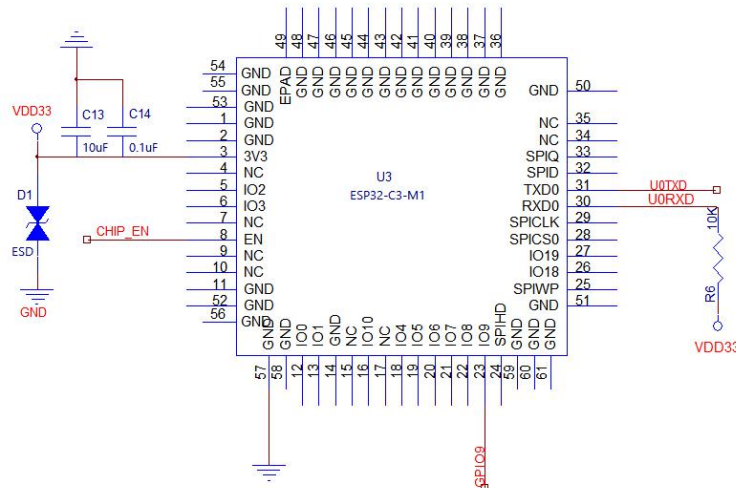

Figure 9 Antenna field pattern

## 7. Design guidance

### 7.1. Module application guidance circuit

(>= 500mA, it is recommended to use DC-DC or LDO independent power supply)



**Figure 10 Application circuit diagram**

Notice:

- IO20 is used as U0RXD, and a pull-up resistor needs to be added externally.
- IO9 is the startup control pin, it is in normal working mode when high level, and it is in firmware programming mode when low level. The internal default high level of the chip.

### 7.2. Antenna layout requirements

- For the installation position on the motherboard, the following two methods are recommended:

Solution 1: Put the module on the edge of the main board, and the antenna area extends out of the edge of the main board.

Solution 2: Put the module on the edge of the motherboard, and hollow out an area at the antenna position on the edge of the motherboard.

- In order to meet the performance of the on-board antenna, it is forbidden to place metal parts around the antenna, away from high-frequency components.

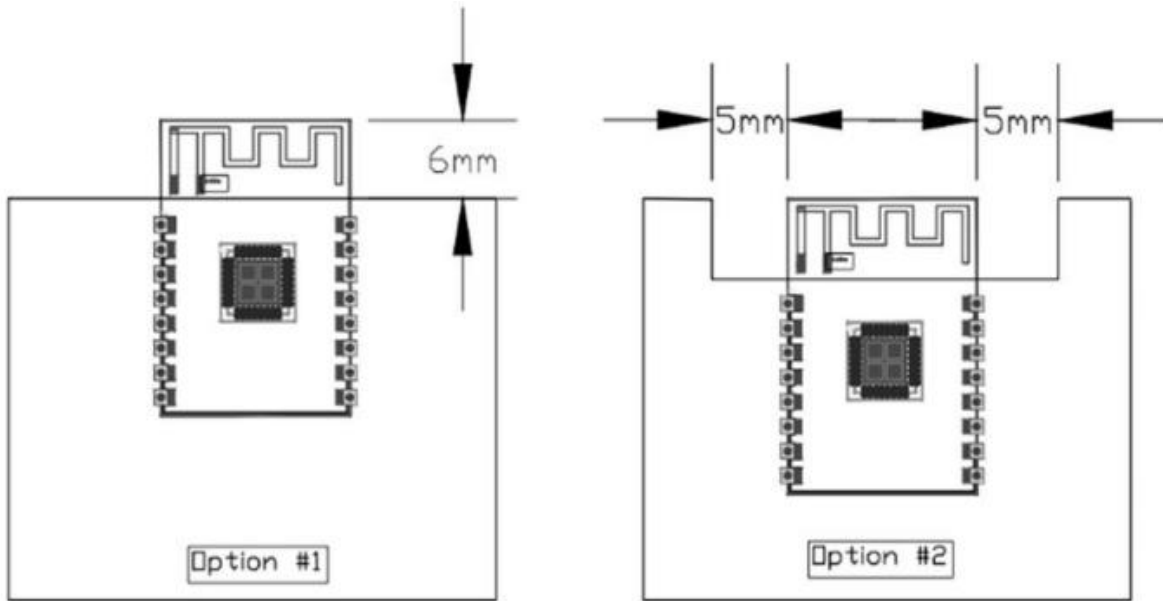

Figure 11 Schematic diagram of antenna layout

### 7.3. Power supply

- Recommended 3.3V voltage, peak current above 500mA.
- It is recommended to use LDO for power supply; if using DC-DC, it is recommended that the ripple be controlled within 30mV.
- For the DC-DC power supply circuit, it is recommended to reserve a place for the dynamic response capacitor to optimize the output ripple when the load changes greatly.
- It is recommended to add ESD devices to the 3.3V power interface

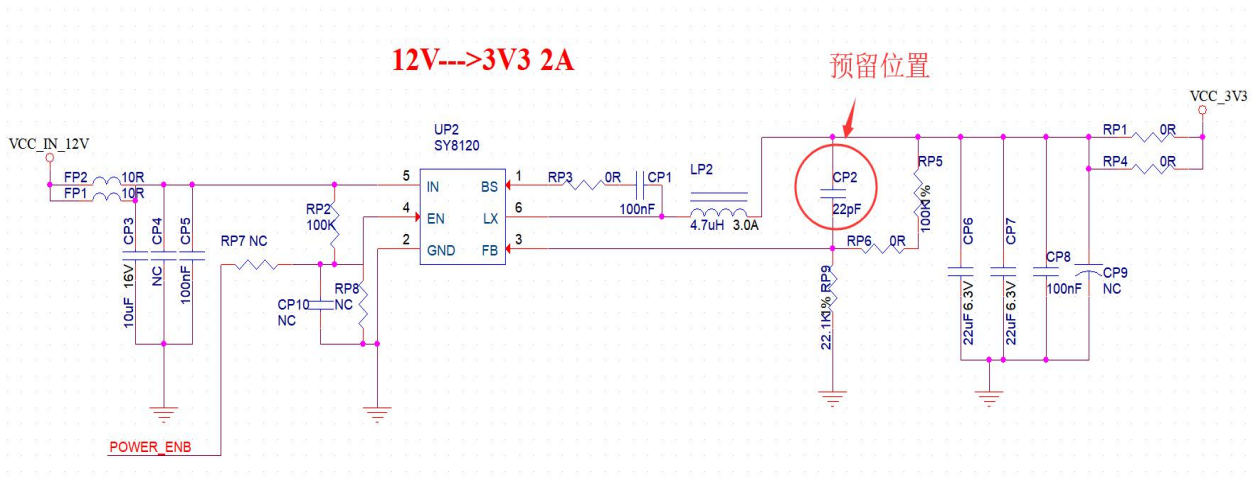

Figure 12 DC-DC step-down circuit diagram

## 7.4. The use of GPIO interface

- There are some IO ports on the periphery of the module. If you need to use it, it is recommended to connect a 10-100 ohm resistor in series with the IO port. This can suppress overshoot and make the levels on both sides more stable. It is helpful for EMI and ESD.
- For the pull-up and pull-down of special IO ports, please refer to the instructions in the specification. This will affect the startup configuration of the module.
- The IO port of the module is 3.3V. If the main control and the IO port level of the module do not match, a level conversion circuit is required.
- If the IO port is directly connected to a peripheral interface, or a terminal such as a header, it is recommended to reserve an ESD device near the terminal when the IO port is routed

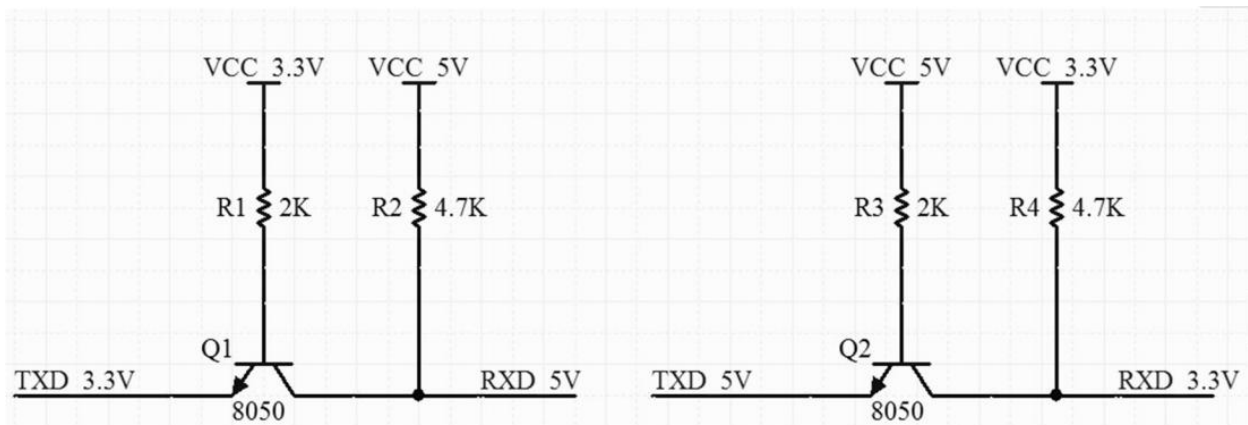

Figure 13 Level conversion circuit

## 8. Reflow soldering curve diagram

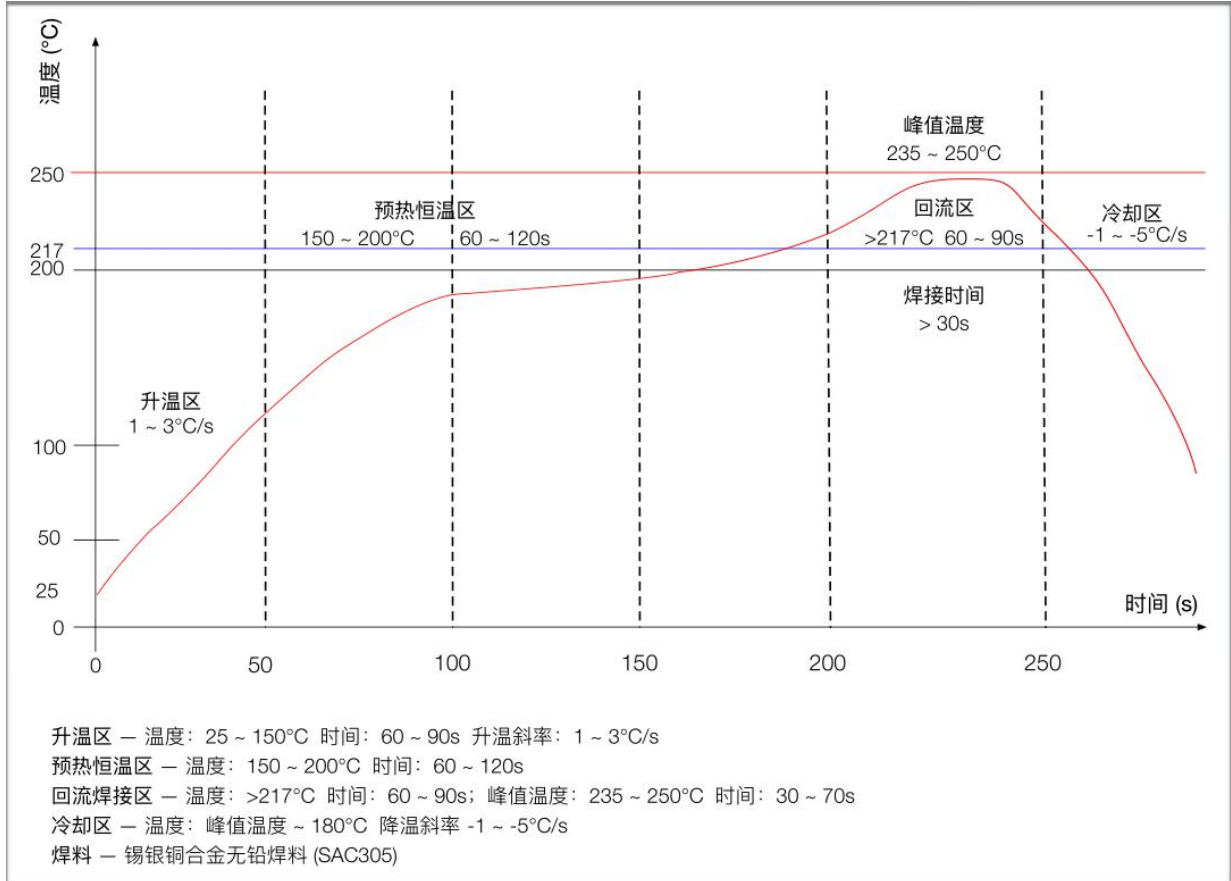

Figure 14 Reflow soldering curve

## 9. Product related models

**Table 9 Product related model list**

产品型号	供电	封装	尺寸	天线接口
ESP-C3-12F	3.0V ~ 3.6V, I>500mA	SMD-22	24.0*16.0*3.1( ±0.2)mm	The on-board PCB antenna or external antenna connector is compatible
ESP-C3-32S	3.0V ~ 3.6V, I>500mA	SMD-38	25.5*18.0*3.1( ±0.2)mm	
ESP-C3-13	3.0V ~ 3.6V, I>500mA	SMD-18	20.0*18.0*3.1( ±0.2)mm	
ESP-C3-13U	3.0V ~ 3.6V, I>500mA	SMD-18	14.0*18.0*3.1( ±0.2)mm	IPEX interface
ESP-C3-01M	3.0V ~ 3.6V, I>500mA	DIP-18 Gold finger plug-in	18.0*18.0*2.8( ±0.2)mm	On-board PCB antenna
ESP-C3-M1 (-85°C version module/ -105°C version module)	3.0V ~ 3.6V, I>500mA	SMD-61	16.6*13.2*2.4( ±0.2)mm	On-board PCB antenna
ESP-C3-M1-I (-85°C version module/ -105°C version module)	3.0V ~ 3.6V, I>500mA	SMD-61	12.5*13.2*2.4( ±0.2) mm	IPEX interface
ESP-C3-12F-Kit	5V, I>500mA	DIP-30	48.26*25.4(± 0.2)mm	The on-board PCB antenna or external antenna connector is compatible
ESP-C3-32S-Kit	5V, I>500mA	DIP-30	48.26*25.4(± 0.2)mm	
ESP-C3-13-Kit	5V, I>500mA	DIP-30	48.26*25.4(± 0.2)mm	
ESP-C3-13U-Kit	5V, I>500mA	DIP-30	48.26*25.4(± 0.2)mm	IPEX interface
ESP-C3-01M-Kit	5V, I>500mA	DIP-20	31.3*28.5(± 0.2)mm	On-board PCB antenna
ESP-C3-M1-Kit (-85°C version module/ -105°C version module)	5V, I>500mA	DIP-30	48.26*25.4(± 0.2)mm	On-board PCB antenna
ESP-C3-M1-I-Kit (-85°C version module/ -105°C version module)	5V, I>500mA	DIP-30	48.26*25.4(± 0.2)mm	IPEX interface
产品相关信息： <a href="https://docs.ai-thinker.com">https://docs.ai-thinker.com</a>				

## 10. Packaging information

ESP-C3-M1 module was packaged in a tape, 900pcs /pcs. As shown in the below image:



Figure 15 Package and packing diagram

## 11. Contact us

[Ai-Thinker official website](#)

[Office forum](#)

[Develop DOCS](#)

[LinkedIn](#)

[Tmall shop](#)

[Taobao shop](#)

[Alibaba shop](#)

Technic support email: [support@aithinker.com](mailto:support@aithinker.com)

Domestic business cooperation: [sales@aithinker.com](mailto:sales@aithinker.com)

Overseas business cooperation: [overseas@aithinker.com](mailto:overseas@aithinker.com)

Company Address: Room 403,408-410, Block C, Huafeng Smart Innovation Port, Gushu 2nd Road, Xixiang, Baoan District, Shenzhen.

Tel: +86-0755-29162996



Wechat mini program



Wechat official account

## Disclaimer and copyright notice

The information in this article, including the URL address for reference, is subject to change without notice.

The document is provided "as is" without any guarantee responsibility, including any guarantee for marketability, suitability for a specific purpose, or non-infringement, and any guarantee mentioned elsewhere in any proposal, specification or sample. This document does not bear any responsibility, including the responsibility for infringement of any patent rights caused by the use of the information in this document. This document does not grant any license for the use of intellectual property rights in estoppel or other ways, whether express or implied.

The test data obtained in the article are all obtained from Ai-Thinker's laboratory test, and the actual results may vary slightly.

All brand names, trademarks and registered trademarks mentioned in this article are the property of their respective owners, and it is hereby declared.

The final interpretation right belongs to Shenzhen Ai-Thinker Technology Co., Ltd.

## Notice

Due to product version upgrades or other reasons, the contents of this manual may be changed.

Shenzhen Ai-Thinker Technology Co., Ltd. reserves the right to modify the contents of this manual without any notice or prompt.

This manual is only used as a guide. Shenzhen Ai-thinker Technology Co., Ltd. makes every effort to provide accurate information in this manual. However, Shenzhen Ai-Thinker Technology Co., Ltd. does not guarantee that the contents of the manual are completely free of errors. All statements and information in this manual And the suggestion does not constitute any express or implied guarantee.