



# ESP-C3-M1-Kit Specification

Version V1.2.0

Copyright©2021





## Content

1. Product Overview.....	4
2. Main parameters.....	5
2.1. Static electricity requirements.....	6
2.2. Electrical characteristics.....	7
2.3. WiFi RF performance.....	7
2.4. BLE RF performance.....	8
2.5. Power consumption.....	8
3. Appearance dimensions.....	9
4. Indicator and button description.....	10
5. Pin definition.....	11
6. Schematic.....	13
7. Product related models.....	14
8. Product packaging information.....	15
9. Contact us.....	15
Disclaimer and copyright notice.....	16
Notice.....	16

## 1. Product Overview

The ESP-C3-M1-Kit development board is a core development board designed by Ai-Thiner for the ESP-C3-M1 module. The development board continues the classic design of the NodeMCU development board, lead all I/O to the pins on both sides, developers can connect peripherals according to their needs. When using a breadboard for development and debugging, the 2.54mm pitch pin headers on both sides can make the operation easier and more convenient.

The main control chip of the development board is the ESP32-C3 chip. The ESP32-C3 chip has industry-leading low power consumption performance and radio frequency performance, and supports WiFi IEEE802.11b/g/n protocol and BLE 5.0. The chip is equipped with a RISC-V 32-bit single-core processor with a working frequency of up to 160 MHz. Support secondary development without using other microcontrollers or processors. The chip has built-in 400 KB SRAM, 384 KB ROM, 8KB RTC SRAM, and built-in 4MB Flash. The chip supports a variety of low power consumption working states, which can meet the power consumption requirements of various application scenarios. The chip's unique features such as fine clock gating function, dynamic voltage clock frequency adjustment function, and RF output power adjustable function can achieve the best balance between communication distance, communication rate and power consumption.

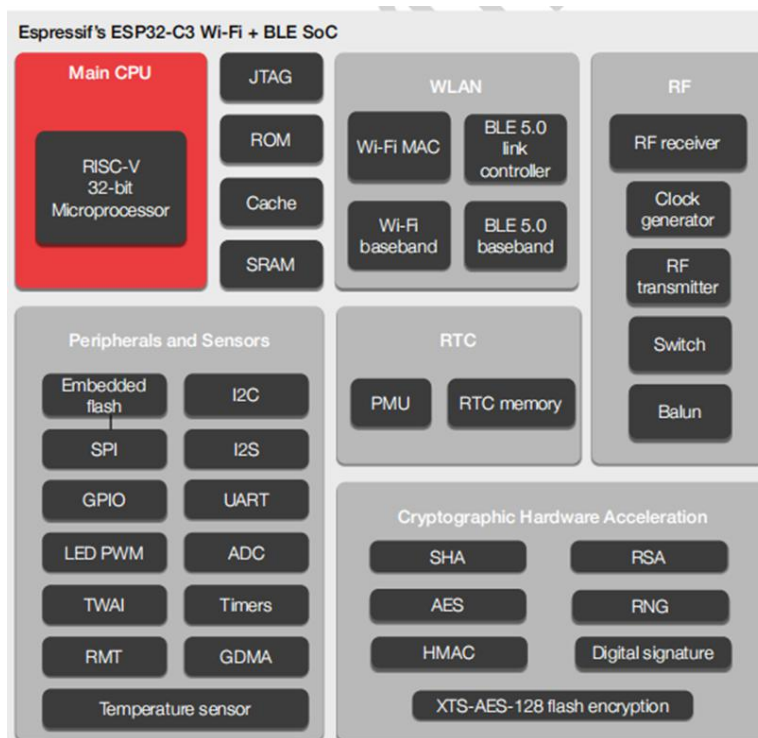

**Figure 1 Architecture diagram of the main control chip**

### ■ Processor:

- ✓ RISC-V 32-bit single-core processor
- ✓ Configurable CPU frequency up to 160MHz
- ✓ Universal DMA controller, 3 receiving channels and 3 sending channels
- Memory:
  - ✓ Built-in 4MB flash, does not support expansion
  - ✓ 384 KB ROM
  - ✓ 400 KB SRAM (Of which 16 KB is dedicated to cache)
  - ✓ 8 KB RTC SRAM
- Wireless characteristics:
  - ✓ Support WiFi 802.11b/g/n, 1T1R mode data rate up to 150Mbps
  - ✓ Support BLE5.0, rate support: 125Kbps, 500Kbps, 1Mbps, 2Mbps
- Peripherals:
  - ✓ 16 GPIO interfaces (including TX0\RX0 and USB\_D-\USB\_D+)
  - ✓ 2 UART interfaces, supports hardware flow control and software flow control, the serial port rate can reach up to 5Mbps
  - ✓ 2 12-bit SAR ADC, supporting 6 analog channel inputs in total
  - ✓ 1 channel I2C, supporting 100 Kbit/s, 400 Kbit/s and up to 800 Kbit/s
  - ✓ 1 channel I2S, support full-duplex or half-duplex mode
  - ✓ 6 independent PWM, 2 timer groups (each timer group has 1 general timer and 1 watchdog), 2 52-bit counters
  - ✓ 3 SPI, SPI0 and SPI1 can only be configured in SPI memory mode, SPI2 can be configured as memory mode or general SPI mode
- Power consumption mode:
  - ✓ Active mode: CPU and chip radio frequency are working
  - ✓ Modem-sleep mode: CPU can run, clock frequency can be configured
  - ✓ Light-sleep mode: CPU suspended
  - ✓ Deep-sleep mode: The CPU and most peripherals will be powered down, and only the RTC memory is in working condition. The deep sleep current is less than 5uA.
- Application:
  - ✓ Support STA/AP/STA+AP mode and promiscuous mode
  - ✓ Support Smart Config (APP)/AirKiss (WeChat) for Android and IOS one-click network configuration
  - ✓ Support serial port local upgrade and remote firmware upgrade (FOTA)
  - ✓ General AT commands can be used quickly
  - ✓ Support secondary development, integrated Windows, Linux development environment

## 2. Main parameters

**Table 1 Description of main parameters**

<b>Development board model</b>	ESP-C3-M1-Kit
<b>Suitable module</b>	ESP-C3-M1
<b>Package</b>	DIP-30 (2.54mm pitch standard pin header)
<b>Size</b>	48.26*25.4(±0.2)mm
<b>Antenna</b>	On-board PCB antenna
<b>Operating temperature</b>	-40 °C ~ 85 °C
<b>Storage environment</b>	-40 °C ~ 125 °C, < 90%RH
<b>Power supply range</b>	Voltage: 5V, Electrical current $\geq$ 500mA
<b>Support Interface</b>	UART/I2C/PWM/ADC/GPIO/SPI/I2S
<b>IO</b>	16 GPIO(including TX0\RX0 and USB_D-\USB_D+)
<b>UART Rate</b>	Support 110 ~ 4608000 bps, default 115200 bps
<b>Bluetooth</b>	BLE 5.0, does not support traditional Bluetooth
<b>Security</b>	WEP/WPA-PSK/WPA2-PSK
<b>Flash</b>	Built-in 4MB Flash

## 2.1. Static electricity requirements

The ESP-C3-M1-Kit development board is an electrostatic sensitive device, and special precautions must be taken when handling it.



**Figure 2 ESD anti-static diagram**

## 2.2. Electrical characteristics

**Table 2 Electrical characteristics table**

Parameters	Conditions	Min	Typical Values	Max	Unit	
Supply voltage	VDD	-	5	-	V	
I/O	$V_{IL}/V_{IH}$	-	-0.3/0.75VDD	-	$0.25V_{DD}/V_{DD} + 0.3$	V
	$V_{OL}/V_{OH}$	-	N/0.8VIO	-	0.1VIO/N	V
	$I_{MAX}$	-	-	-	12	mA

## 2.3. WiFi RF performance

**Table 3 WiFi RF performance table**

Description	Typical values	Unit
Working frequency	2400 - 2483.5	MHz
<b>Output power</b>		
11n mode HT40, PA output power	$15 \pm 2$	dBm
11n mode HT20, PA output power	$15 \pm 2$	dBm
11g mode, PA output power	$16 \pm 2$	dBm
11b mode, PA output power	$18 \pm 2$	dBm
<b>Receiving sensitivity</b>		
11b, 1 Mbps	$\leq -94$	dBm
11b, 11 Mbps	$\leq -86$	dBm
11g, 6 Mbps	$\leq -90$	dBm
11g, 54 Mbps	$\leq -73$	dBm
11n, HT20 (MCS7)	$\leq -71$	dBm
11n, HT40 (MCS7)	$\leq -68$	dBm

## 2.4. BLE RF performance

**Table 4 BLE RF performance table**

Description	Typical Values	Unit
<b>Output power</b>		
Transmit power	$9 \pm 2$	dBm
<b>Receiving sensitivity Low Energy consumption BLE: 1M</b>		
Sensitivity@30.8%PER	$\leq -94$	dBm

## 2.5. Power consumption

The following power consumption data is based on 5V power supply, 25°C ambient temperature, and measured with internal voltage regulator.

- All measurements are done at the antenna interface without SAW filter.
- All emission data is based on 100% duty cycle, measured in continuous emission mode.

**Table 5 Power consumption table**

Mode	Min	Average value	Max	Unit
Tx 802.11b, DSSS 1Mbps, POUT=+20dBm	-	350	-	mA
Tx 802.11g, OFDM 54Mbps, POUT =+18dBm	-	290	-	mA
Tx 802.11n, MCS7, POUT =+17dBm	-	280	-	mA
Rx 802.11b, 1024 bit	-	90	-	mA
Rx 802.11g, 1024 bit	-	90	-	mA
Rx 802.11n, 1024 bit	-	93	-	mA
Modem-Sleep <sup>①</sup>	-	20	-	mA
Light-Sleep <sup>②</sup>	-	130	-	μA
Deep-Sleep <sup>③</sup>	-	5	-	μA
Power Off	-	1	-	μA

### 3. Appearance dimensions

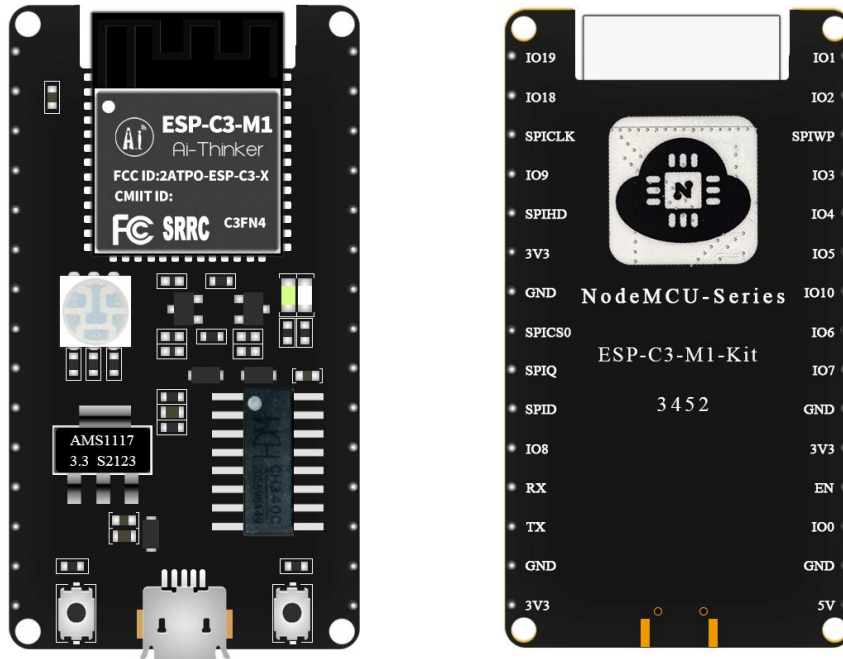

**Figure 3 Appearance of ESP-C3-M1-Kit (the picture and cover printing are for reference only, the actual product shall prevail)**

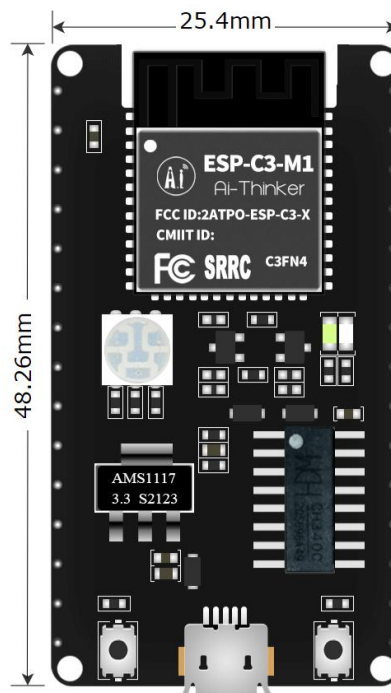

**Figure 4 Development board size diagram**

## 4. Indicator and button description

ESP-C3-M1-Kit has 2 indicator lights, 1 RGB light, and two buttons. The keys are: "RST" key and "BOOT" key, as shown in the figure below:

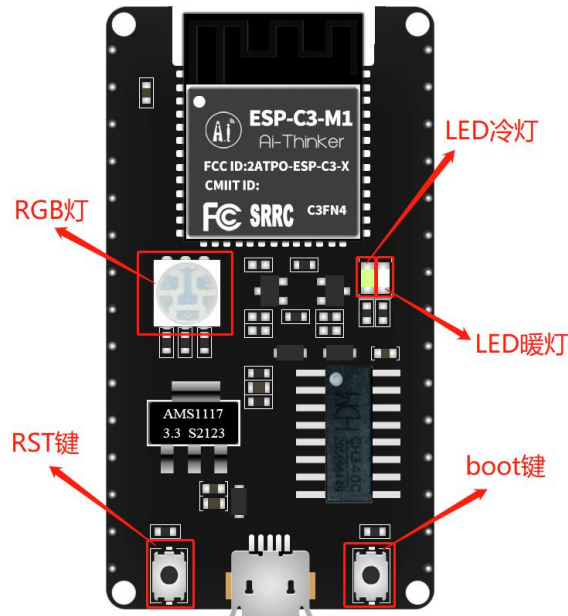

Figure 5 ESP-C3-M1-Kit indicator and button location

Table 6 Indicator status and key function table

Indicator light or button	LED status or button function	Remark
RGB light	RGB lights are respectively connected to IO3, IO4, IO5 of the development board	The three IO pins of the RGB lamp correspondingly control the three primary colors of red, green and blue
LED cold or warm light	LED cold light and warm light are respectively connected to IO19 and IO18 of MCU	LED cold light and warm light are used for status indication, customers can configure according to their needs
RST button	Reset button	/
BOOT button	Set the development board to enter the burning mode	/



## 5. Pin definition

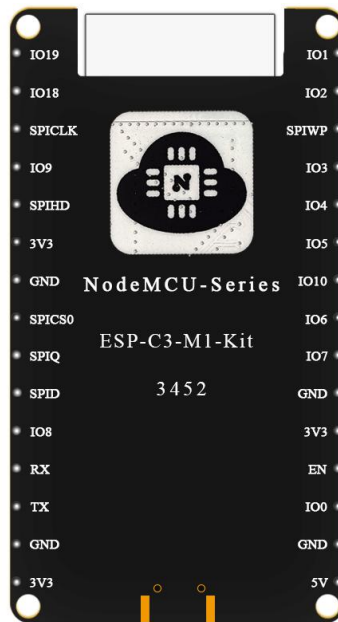

**Figure 6 Schematic diagram of development board pins (bottom view)**

ESP-C3-M1-Kit has a total of 30 interfaces. As shown in the above pin diagram, the pin function definition table is the interface definition.

**Table 7 Pin function definition table**

No	Name	Function
1	IO1	GPIO1,ADC1_CH1,XTAL_32K_N
2	IO2	GPIO2,ADC1_CH2,FSPIQ
3	SPIWP	NC, not recommended
4	IO3	GPIO3,ADC1_CH3
5	IO4	GPIO4,ADC1_CH4,FSPIHD,MTMS
6	IO5	GPIO5,ADC2_CH4,FSPIWP,MTDI
7	IO10	GPIO10,FSPICS0
8	IO6	GPIO6,FSPICLK,MTCK
9	IO7	GPIO7,FSPID,MTDO
10	GND	Grounded Power negative
11	3V3	3.3V

12	EN	High level: chip enabled; Low level: chip shutdown;
13	IO0	GPIO0,ADC1_CH0,XTAL_32K_P
14	GND	Grounded Power negative
15	5V	Power supply Power positive
16	3V3	3.3V
17	GND	Grounded Power negative
18	TX	U0TXD,GPIO21
19	RX	U0RXD,GPIO20
20	IO8	GPIO8
21	SPID	NC, not recommended
22	SPIQ	NC, not recommended
23	SPICS0	NC, not recommended
24	GND	Grounded Power negative
25	3V3	3.3V
26	SPIHD	NC, not recommended
27	IO9	GPIO9
28	SPICLK	NC, not recommended
29	IO18	GPIO18,USB_D-
30	IO19	GPIO19,USB_D+

## 6. Schematic

ESP-C3-M1-Kit and ESP-C3-M1-I-Kit share the same schematic diagram.

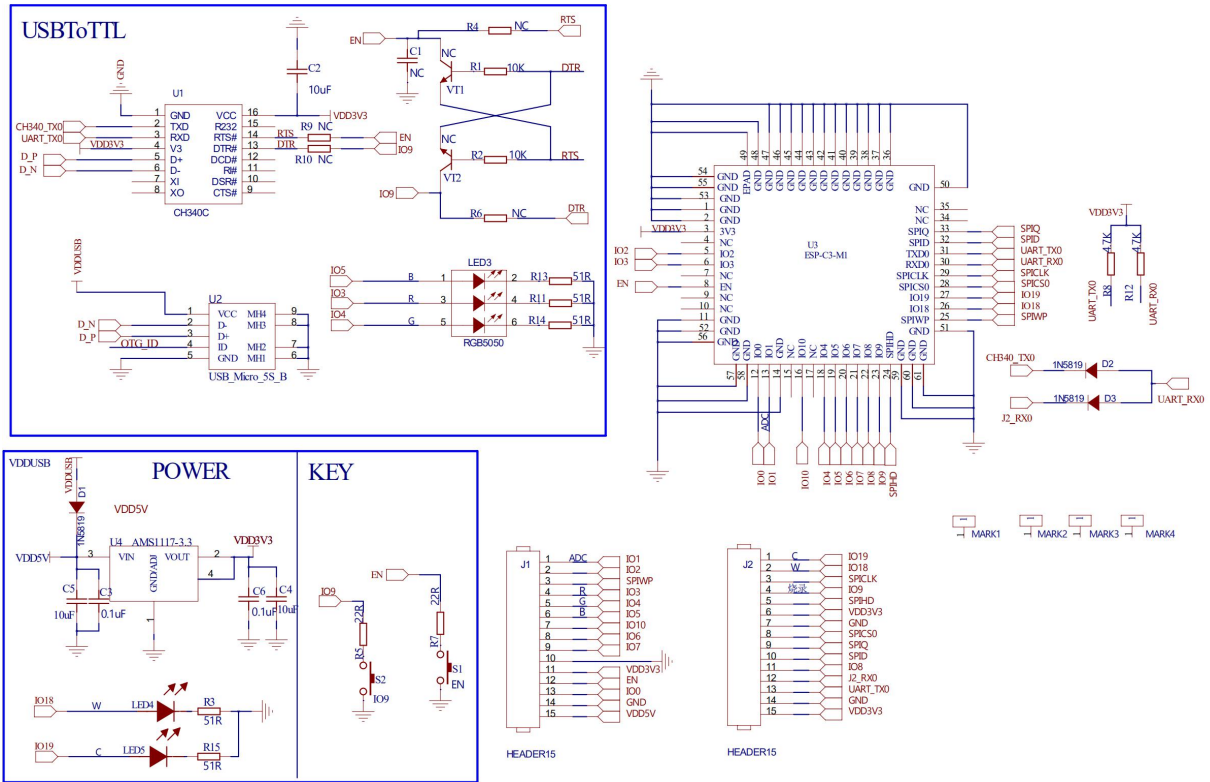

**Figure 7 Schematic diagram of the development board**

## 7. Product related models

**Table 8 Product related model list**

Model	Power Supply	Package	Size	Antenna
ESP-C3-12F	3.0V ~ 3.6V, I>500mA	SMD-22	24.0*16.0*3.1( ±0.2)mm	The on-board PCB antenna or external antenna connector is compatible
ESP-C3-32S	3.0V ~ 3.6V, I>500mA	SMD-38	25.5*18.0*3.1( ±0.2)mm	
ESP-C3-13	3.0V ~ 3.6V, I>500mA	SMD-18	20.0*18.0*3.1( ±0.2)mm	
ESP-C3-13U	3.0V ~ 3.6V, I>500mA	SMD-18	14.0*18.0*3.1( ±0.2)mm	IPEX interface
ESP-C3-01M	3.0V ~ 3.6V, I>500mA	DIP-18 Gold finger plug-in	18.0*18.0*2.8( ±0.2)mm	On-board PCB antenna
ESP-C3-M1 (-85°C version module/ -105°C version module)	3.0V ~ 3.6V, I>500mA	SMD-61	16.6*13.2*2.4( ±0.2)mm	On-board PCB antenna
ESP-C3-M1-I (-85°C version module/ -105°C version module)	3.0V ~ 3.6V, I>500mA	SMD-61	12.5*13.2*2.4( ±0.2) mm	IPEX interface
ESP-C3-12F-Kit	5V, I>500mA	DIP-30	48.26*25.4(± 0.2)mm	The on-board PCB antenna or external antenna connector is compatible
ESP-C3-32S-Kit	5V, I>500mA	DIP-30	48.26*25.4(± 0.2)mm	
ESP-C3-13-Kit	5V, I>500mA	DIP-30	48.26*25.4(± 0.2)mm	
ESP-C3-13U-Kit	5V, I>500mA	DIP-30	48.26*25.4(± 0.2)mm	IPEX interface
ESP-C3-01M-Kit	5V, I>500mA	DIP-20	31.3*28.5(± 0.2)mm	On-board PCB antenna
ESP-C3-M1-Kit (-85°C version module/ -105°C version module)	5V, I>500mA	DIP-30	48.26*25.4(± 0.2)mm	On-board PCB antenna
ESP-C3-M1-I-Kit (-85°C version module/ -105°C version module)	5V, I>500mA	DIP-30	48.26*25.4(± 0.2)mm	IPEX interface
Product related information: <a href="https://docs.ai-thinker.com">https://docs.ai-thinker.com</a>				

## 8. Product packaging information

Table 9 Packaging Information Table

Packing list	Modes of Packing	Quantity per pack (Electrostatic bag)	Quantity per pack (sealed bag)
ESP-C3-M1-Kit	Foam+static bag	1pcs	20pcs

## 9. Contact us

[Ai-Thinker official website](#)

[Office forum](#)

[Develop DOCS](#)

[LinkedIn](#)

[Tmall shop](#)

[Taobao shop](#)

[Alibaba shop](#)

[Technic support email: support@aithinker.com](mailto:support@aithinker.com)

[Domestic business cooperation: sales@aithinker.com](mailto:sales@aithinker.com)

[Overseas business cooperation: overseas@aithinker.com](mailto:overseas@aithinker.com)

Company Address: Room 403,408-410, Block C, Huafeng Smart Innovation Port, Gushu 2nd Road, Xixiang, Baoan District, Shenzhen.

Tel: +86-0755-29162996



Wechat mini program



Wechat official account

## Disclaimer and copyright notice

The information in this article, including the URL address for reference, is subject to change without notice.

The document is provided "as is" without any guarantee responsibility, including any guarantee for merchantability, suitability for a specific purpose, or non-infringement, and any guarantee mentioned elsewhere in any proposal, specification or sample. This document does not bear any responsibility, including the responsibility for infringement of any patent rights arising from the use of the information in this document. This document does not grant any license for the use of intellectual property rights in estoppel or other ways, whether express or implied.

The test data obtained in the article are all obtained from Ai-Thinker's laboratory tests, and the actual results may vary slightly.

The Wi-Fi Alliance member logo is owned by the Wi-Fi Alliance.

All brand names, trademarks and registered trademarks mentioned in this article are the property of their respective owners, and it is hereby declared.

The final interpretation right belongs to Shenzhen Ai-Thinker Technology Co., Ltd.

## Notice

Due to product version upgrades or other reasons, the contents of this manual may be changed.

Shenzhen Ai-Thinker Technology Co., Ltd. reserves the right to modify the contents of this manual without any notice or prompt.

This manual is only used as a guide. Shenzhen Ai-Thinker Technology Co., Ltd. makes every effort to provide accurate information in this manual. However, Shenzhen Ai-Thinker Technology Co., Ltd. does not guarantee that the contents of the manual are completely free of errors. All statements and information in this manual And the suggestion does not constitute any express or implied guarantee.